

Material Specifications

Left Connector: C1005
 Right Connector: C1005
 Cable: RG59

NOTES:

1. XX EQUALS LENGTH IN INCHES

 <p>Federal Custom Cable www.FCCable.com</p> <p>1891 Alton Parkway, Irvine, CA 92606 Phone: (949) 851-3114 Fax: (949) 852-8136 Sales@FCCable.com</p>	<p>CAGE CODE 1UKX3</p>	<p>Part Number: CA1002-XX</p>	<p>Description: BNC FEMALE TO BNC FEMALE COAX CABLE ASSEMBLY WITH RG59 FLEXIBLE CABLE</p>
	<p>Dimensions Millimeters Inches</p>		
	<p>Scale: N/A</p>	<p>NOTES: 1. DIMENSIONS ARE IN MILLIMETERS INCHES 2. UNLESS OTHERWISE SPECIFIED ALL DIMENSIONS ARE NOMINAL 3. SPECIFICATIONS ARE SUBJECT TO CHANGE WITHOUT NOTICE</p>	<p>THIS DRAWING CONTAINS PROPRIETART INFORMATION THAT BELONGS TO FEDERAL CUSTOM CABLE, LLC. ANY UNAUTHORIZED USE OF THIS DRAWING IS PROHIBITED WITHOUT WRITTEN PERMISSION FROM FEDERAL CUSTOM CABLE. ALL RIGHTS RESERVED. ©2020 COPYRIGHT FEDERAL CUSTOM CABLE, LLC.</p>
	<p>Revision:</p>		

RG59B/U

75-Ohm Flexible Coax Cable; 0.242" Diameter, Single Shield, Black PVC(NC) Jacket



PART NUMBER:	RG59B/U
CATAGORY:	FLEXIBLE
DESCRIPTION:	CABLE
IMPEDANCE:	75 OHMS
DIELECTRIC:	POLYETHYLENE
OUTSIDE DIAMETER:	0.146"
NOMINAL OUTSIDE DIAMETER:	0.242"
QUALIFICATION:	M17/29-RG059

PHYSICAL CHARACTERISTICS:

OUTER CONDUCTOR & TYPE OF SHIELD:	94% BARE COPPER, 2.6 OHM/1000FT
JACKET MATERIAL:	POLYVINYL CHLORIDE-II A, BLACK
OVER-BRAID:	N/A
INNER CONDUCTOR:	0.0266, COPPER CLAD STEEL, 23 AWG, 47.0 OHM/1000FT NOMINAL DIRECT CURRENT RESISTANCE

ELECTRICAL CHARACTERISTICS:

NOMINAL CAPACITANCE (PICO FARAD/FT):	19.5
VELOCITY OF PROPAGATION:	66%
MAXIMUM OPERATING FREQUENCY (GHz):	1.0
MAXIMUM OPERATING RANGE (C):	-40 TO +85
MAXIMUM ATTENUATION:	dB (MHz/100FT)
A. 50 MHz:	2.4
B. 100 MHz:	3.4
C. 200 MHz:	4.9
D. 400 MHz:	9.0
E. 1000 MHz:	16.0
QUALIFICATION TEST REPORT#:	17-074-90
APPROX WT/1000FT:	35 LBS.

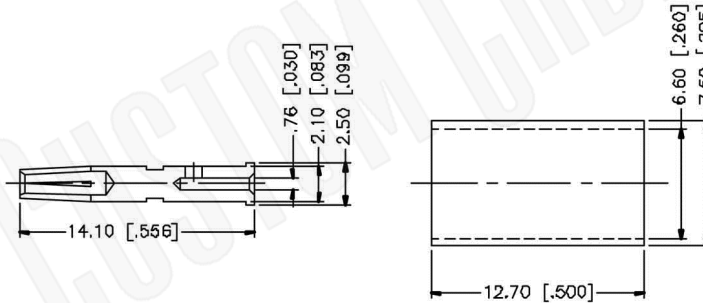
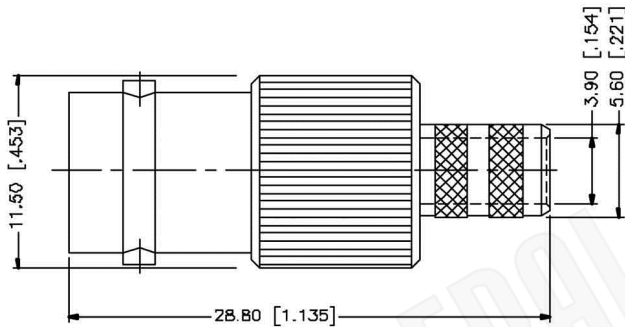
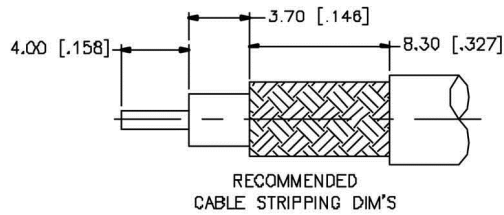

NOTE:

1. CRIMPED FERRULE
HEX CRIMP SIZE .213"
2. CRIMPED CONTACT PIN
HEX CRIMP SIZE .068"

Material Specifications

Cable(s): RG59,62,140,210
 Body: Brass
 Finish: Nickel
 Insulation: Delrin
 Impedence: 50 Ohms



Federal Custom Cable
www.FCCable.com

CAGE CODE
1UKX3

Part Number:

Description:

C1005

**BNC FEMALE CONNECTOR CRIMP FOR RG59, RG62,
 RG140, RG210 CABLES**

Dimensions
Millimeters | Inches

Scale: N/A

Revision:

NOTES:
 1. DIMENSIONS ARE IN MILLIMETERS | INCHES
 2. UNLESS OTHERWISE SPECIFIED ALL DIMENSIONS ARE NOMINAL
 3. SPECIFICATIONS ARE SUBJECT TO CHANGE WITHOUT NOTICE

THIS DRAWING CONTAINS PROPRIETARY INFORMATION THAT BELONGS TO FEDERAL CUSTOM CABLE, LLC. ANY UNAUTHORIZED USE OF THIS DRAWING IS PROHIBITED WITHOUT WRITTEN PERMISSION FROM FEDERAL CUSTOM CABLE. ALL RIGHTS RESERVED. ©2016 COPYRIGHT FEDERAL CUSTOM CABLE, LLC.

1891 Alton Parkway, Irvine, CA 92606
 Phone: (949) 851-3114 | Fax: (949) 852-8136

Sales@FCCable.com