

Material Specifications

Left Connector: C1021
 Right Connector: C2005
 Cable: RG8

NOTES:

1. XX EQUALS LENGTH IN INCHES
2. LF DESIGNATES LEAD FREE SOLDER

 Federal Custom Cable www.FCCable.com 1891 Alton Parkway, Irvine, CA 92606 Phone: (949) 851-3114 Fax: (949) 852-8136 Sales@FCCable.com	CAGE CODE 1UKX3	Part Number: CA1017LF-XX	Description: BNC MALE TO BNC FEMALE COAX CABLE ASSEMBLY WITH RG8 FLEXIBLE CABLE ROHS LEAD FREE
	Dimensions Millimeters Inches		
	Scale: N/A	NOTES: 1. DIMENSIONS ARE IN MILLIMETERS INCHES 2. UNLESS OTHERWISE SPECIFIED ALL DIMENSIONS ARE NOMINAL 3. SPECIFICATIONS ARE SUBJECT TO CHANGE WITHOUT NOTICE	THIS DRAWING CONTAINS PROPRIETART INFORMATION THAT BELONGS TO FEDERAL CUSTOM CABLE, LLC. ANY UNAUTHORIZED USE OF THIS DRAWING IS PROHIBITED WITHOUT WRITTEN PERMISSION FROM FEDERAL CUSTOM CABLE. ALL RIGHTS RESERVED. ©2020 COPYRIGHT FEDERAL CUSTOM CABLE, LLC.
	Revision:		

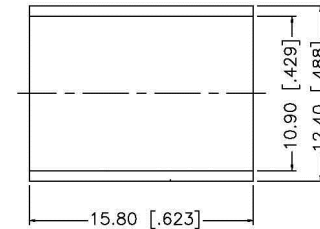
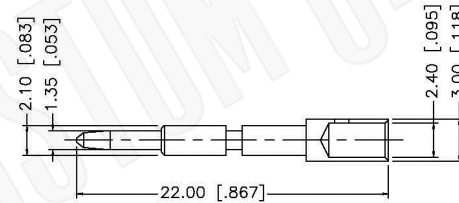
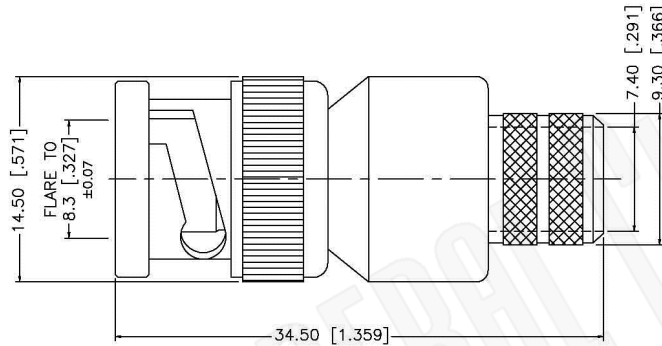
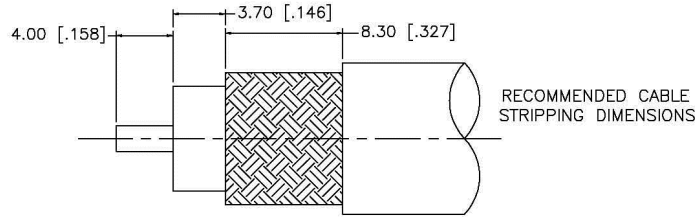

CRIMP NOTES:

1. CRIMPED FERRULE
HEX CRIMP SIZE .429"
2. CRIMPED CONTACT PIN
HEX CRIMP SIZE .100"

Material Specifications

Cable(s): RG8, 8A, 213, 393
 Body: Brass
 Finish: Nickel
 Insulation: Teflon
 Impedence: 50 Ohms



Federal Custom Cable www.FCCable.com 1891 Alton Parkway, Irvine, CA 92606 Phone: (949) 851-3114 Fax: (949) 852-8136 Sales@FCCable.com	CAGE CODE 1UKX3	Part Number: <h1 style="margin: 0;">C1021</h1>	Description: <h2 style="margin: 0;">BNC MALE CONNECTOR CRIMP FOR RG8, RG213, RG393 CABLES</h2>	
	Dimensions Millimeters Inches			
	Scale: N/A	NOTES: 1. DIMENSIONS ARE IN MILLIMETERS INCHES 2. UNLESS OTHERWISE SPECIFIED ALL DIMENSIONS ARE NOMINAL 3. SPECIFICATIONS ARE SUBJECT TO CHANGE WITHOUT NOTICE	THIS DRAWING CONTAINS PROPRIETARY INFORMATION THAT BELONGS TO FEDERAL CUSTOM CABLE, LLC. ANY UNAUTHORIZED USE OF THIS DRAWING IS PROHIBITED WITHOUT WRITTEN PERMISSION FROM FEDERAL CUSTOM CABLE. ALL RIGHTS RESERVED. ©2016 COPYRIGHT FEDERAL CUSTOM CABLE, LLC.	
	Revision:			

RG8A/U

50-Ohm Flexible Coax Cable; 0.405" Diameter, Single Shield, Black PVC(NC) Jacket

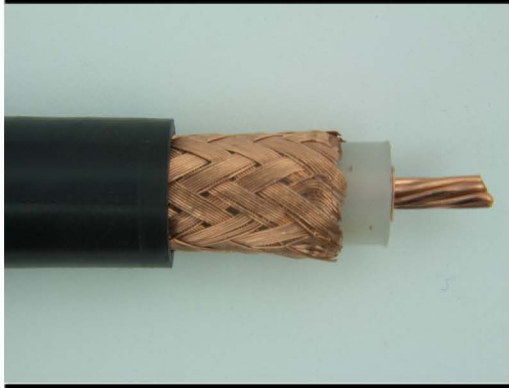

PART NUMBER:	RG8A/U
CATAGORY:	FLEXIBLE
DESCRIPTION:	CABLE
IMPEDANCE:	50 OHMS
DIELECTRIC:	MONO-FILAMENT WRAP AROUND CONDUCTOR
OUTSIDE DIAMETER:	0.285"
NOMINAL OUTSIDE DIAMETER:	0.405"

PHYSICAL CHARACTERISTICS:

JACKET MATERIAL:	TYPE I POLYVINYL CHLORIDE
OVER-BRAID:	N/A
DESCRIPTION ETL/UL/CSA RATING:	RG8/U TYPE LOW LOSS
CENTER CONDUCTOR:	9.5 AWG SOLID BARE COPPER, 6.50 OHM/1000FT NOMINAL DIRECT CURRENT RESISTANCE
OUTER CONDUCTOR & TYPE OF SHIELD:	1ST BONDED ALUMINUM-POLYESTER-ALUMINUM SHIELD TAPE SND 88% TINNED COPPER BRAID

ELECTRICAL CHARACTERISTICS:

NOMINAL CAPACITANCE (PICO FARAD/FT):	24.0
VELICITY OF PROPAGATION:	84%
MAX OPERATING FREQUENCY (GHz):	N/A
MAXIMUM OPERATING RANGE (C):	N/A
MAXIMUM ATTENUATION dB (MHz/100ft):	
A. 50 MHz:	0.9
B. 100 MHz:	1.4
C. 200 MHz:	1.8
D. 400 MHz:	2.6
E. 900 MHz:	4.2
F. 1000 MHz:	4.6
G. 4000 MHz:	11.0
APPROX WT/1000FT:	98 LBS.