

Material Specifications

Left Connector: C1020
 Right Connector: C1005
 Cable: RG62

NOTES:

1. XX EQUALS LENGTH IN INCHES
2. LF DESIGNATES LEAD FREE SOLDER

 Federal Custom Cable www.FCCable.com 1891 Alton Parkway, Irvine, CA 92606 Phone: (949) 851-3114 Fax: (949) 852-8136 Sales@FCCable.com	CAGE CODE 1UKX3	Part Number: CA1021LF-XX	Description: BNC MALE TO BNC FEMALE COAX CABLE ASSEMBLY WITH RG62 FLEXIBLE CABLE ROHS LEAD FREE
	Dimensions Millimeters Inches		
	Scale: N/A	NOTES: 1. DIMENSIONS ARE IN MILLIMETERS INCHES 2. UNLESS OTHERWISE SPECIFIED ALL DIMENSIONS ARE NOMINAL 3. SPECIFICATIONS ARE SUBJECT TO CHANGE WITHOUT NOTICE	THIS DRAWING CONTAINS PROPRIETARY INFORMATION THAT BELONGS TO FEDERAL CUSTOM CABLE, LLC. ANY UNAUTHORIZED USE OF THIS DRAWING IS PROHIBITED WITHOUT WRITTEN PERMISSION FROM FEDERAL CUSTOM CABLE. ALL RIGHTS RESERVED. ©2016 COPYRIGHT FEDERAL CUSTOM CABLE, LLC.
	Revision:		

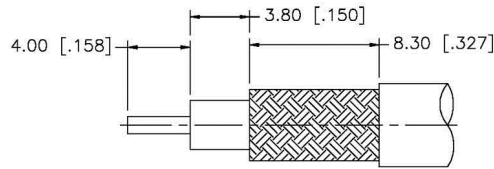

RECOMMENDED
CABLE STRIPPING DIMS.

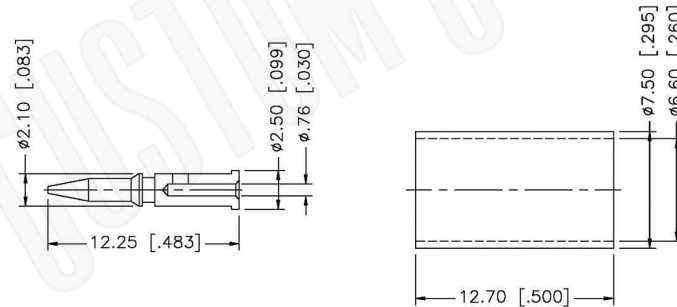
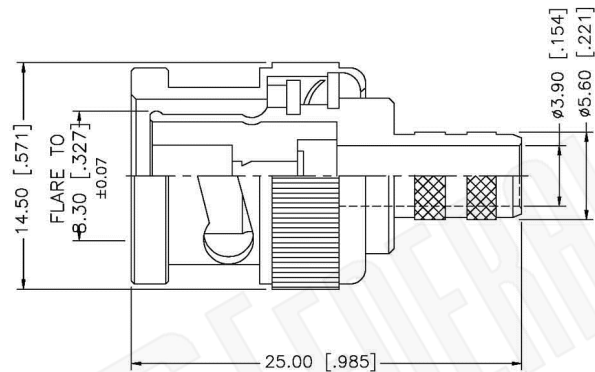

NOTE:

1. CRIMPED FERRULE
HEX. CRIMP SIZE .255"
2. CRIMPED CONTACT PIN
HEX CRIMP SIZE .068"

Material Specifications

Cable(s): RG59,62,140,210
 Body: Brass
 Finish: Nickel
 Insulation: Delrin
 Impedence: 50 Ohms



Federal Custom Cable
www.FCCable.com

CAGE CODE
1UKX3

Part Number:

Description:

C1020

**BNC MALE CONNECTOR CRIMP FOR RG59, RG62,
RG140, RG210 CABLES**

1891 Alton Parkway, Irvine, CA 92606
 Phone: (949) 851-3114 | Fax: (949) 852-8136
Sales@FCCable.com

Dimensions
Millimeters | Inches

Scale: N/A

Revision:

NOTES:
 1. DIMENSIONS ARE IN MILLIMETERS | INCHES
 2. UNLESS OTHERWISE SPECIFIED ALL DIMENSIONS ARE NOMINAL
 3. SPECIFICATIONS ARE SUBJECT TO CHANGE WITHOUT NOTICE

THIS DRAWING CONTAINS PROPRIETARY INFORMATION THAT BELONGS TO FEDERAL CUSTOM CABLE, LLC. ANY UNAUTHORIZED USE OF THIS DRAWING IS PROHIBITED WITHOUT WRITTEN PERMISSION FROM FEDERAL CUSTOM CABLE. ALL RIGHTS RESERVED. ©2016 COPYRIGHT FEDERAL CUSTOM CABLE, LLC.

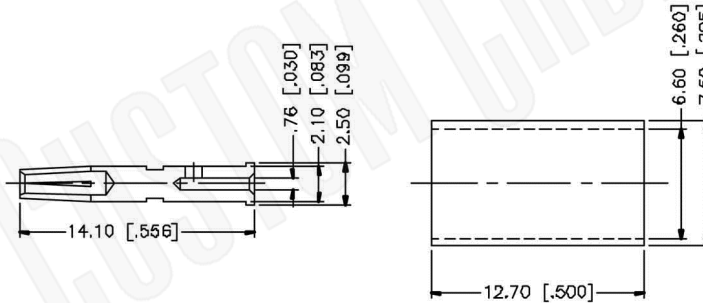
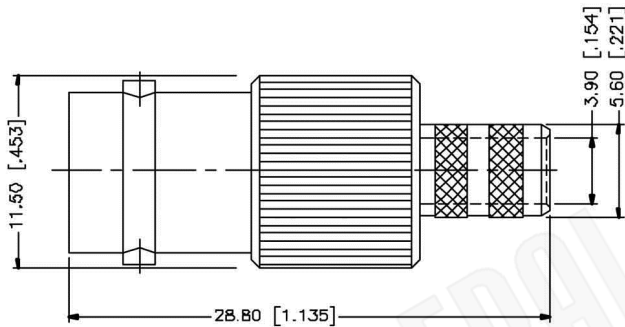
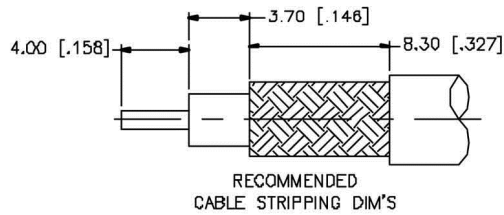

NOTE:

1. CRIMPED FERRULE
HEX CRIMP SIZE .213"
2. CRIMPED CONTACT PIN
HEX CRIMP SIZE .068"

Material Specifications

Cable(s): RG59,62,140,210
 Body: Brass
 Finish: Nickel
 Insulation: Delrin
 Impedence: 50 Ohms



Federal Custom Cable
www.FCCable.com

CAGE CODE
1UKX3

Part Number:

Description:

C1005

**BNC FEMALE CONNECTOR CRIMP FOR RG59, RG62,
 RG140, RG210 CABLES**

Dimensions
Millimeters | Inches

Scale: N/A

Revision:

NOTES:
 1. DIMENSIONS ARE IN MILLIMETERS | INCHES
 2. UNLESS OTHERWISE SPECIFIED ALL DIMENSIONS ARE NOMINAL
 3. SPECIFICATIONS ARE SUBJECT TO CHANGE WITHOUT NOTICE

THIS DRAWING CONTAINS PROPRIETARY INFORMATION THAT BELONGS TO FEDERAL CUSTOM CABLE, LLC. ANY UNAUTHORIZED USE OF THIS DRAWING IS PROHIBITED WITHOUT WRITTEN PERMISSION FROM FEDERAL CUSTOM CABLE. ALL RIGHTS RESERVED. ©2016 COPYRIGHT FEDERAL CUSTOM CABLE, LLC.

1891 Alton Parkway, Irvine, CA 92606
 Phone: (949) 851-3114 | Fax: (949) 852-8136

Sales@FCCable.com

RG62A/U

93-Ohm Flexible Coax Cable; 0.242" Diameter, Single Shield, Black PVC Jacket

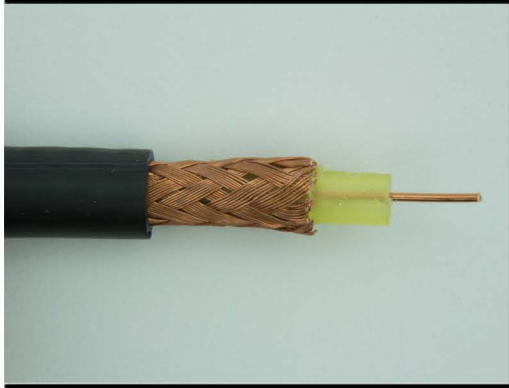

PART NUMBER:	RG62A/U
CATAGORY:	FLEXIBLE
DESCRIPTION:	CABLE
IMPEDANCE:	93.0 OHMS
DIELECTRIC:	SEMI-SOLID POLYETHYLENE
OVERALL DIAMETER:	0.146"
NOMINAL OUTSIDE DIAMETER:	0.242"
QUALIFICATION:	M17/30-RG062

PHYSICAL CHARACTERISTICS:

OVER-BRAID:	N/A
JACKET MATERIAL:	POLYVINYL CHLORIDE-II A, BLACK
OUTER CONDUCTOR & TYPE OF SHIELD:	94% BARE COPPER, 2.9 OHM/1000FT.
INNER CONDUCTOR:	0.0253, COPPER CLAD STEEL, 22 AWG, 41.2 OHM/1000FT. NOMINAL DIRECT CURRENT RESISTANCE
OUTSIDE DIAMETER:	0.146" DIAMETER 0.035" MONOFILAMENT (AIR SPACE)

ELECTRICAL CHARACTERISTICS:

NOMINAL CAPACITANCE (PICO FARAD/FT):	14.0
VELOCITY OF PROPAGATION:	84%
MAXIMUM OPERATING FREQUENCY (GHz):	1.0
MAXIMUM OPERATING RANGE (C):	-40 TO +85
MAXIMUM ATTENUATION:	(dB/100ft)
A. 50 MHz:	1.9
B. 100 MHz:	2.7
C. 200 MHz:	4.1
D. 400 MHz:	8.0
E. 1000 MHz:	13.0
QUALIFICATION TEST REPORT#:	17-075-90
QPPROX WT/1000FT:	38 LBS.