

**Material Specifications**

Left Connector: C1013  
 Right Connector: C1001  
 Cable: RG174

**NOTES:**

1. XX EQUALS LENGTH IN INCHES

 <b>Federal Custom Cable</b> <a href="http://www.FCCable.com">www.FCCable.com</a>  1891 Alton Parkway, Irvine, CA 92606 Phone: (949) 851-3114   Fax: (949) 852-8136 <a href="mailto:Sales@FCCable.com">Sales@FCCable.com</a>	<b>CAGE CODE</b> 1UKX3	<b>Part Number:</b> CA1023-XX	<b>Description:</b> BNC MALE TO BNC FEMALE COAX CABLE ASSEMBLY WITH RG174 FLEXIBLE CABLE
	<b>Dimensions</b> Millimeters   Inches		
	<b>Scale:</b> N/A	<b>NOTES:</b> 1. DIMENSIONS ARE IN MILLIMETERS   INCHES 2. UNLESS OTHERWISE SPECIFIED ALL DIMENSIONS ARE NOMINAL 3. SPECIFICATIONS ARE SUBJECT TO CHANGE WITHOUT NOTICE	THIS DRAWING CONTAINS PROPRIETART INFORMATION THAT BELONGS TO FEDERAL CUSTOM CABLE, LLC. ANY UNAUTHORIZED USE OF THIS DRAWING IS PROHIBITED WITHOUT WRITTEN PERMISSION FROM FEDERAL CUSTOM CABLE. ALL RIGHTS RESERVED. ©2020 COPYRIGHT FEDERAL CUSTOM CABLE, LLC.
	<b>Revision:</b>		

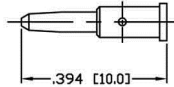
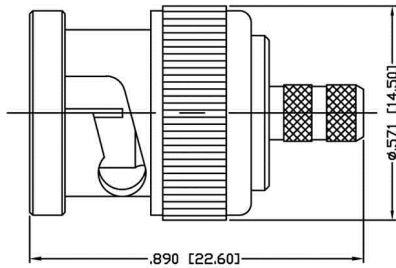

RECOMMENDED CRIMP DIE: .068"

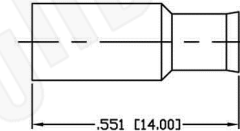
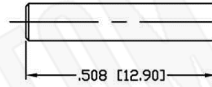

RECOMMENDED CRIMP DIE: .130" & .178"

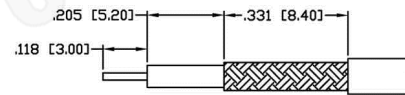

RECOMMENDED STRIPPING DIMENSIONS

### Material Specifications

Cable(s): RG174-RG188-RG316  
 Body: Brass  
 Finish: Nickel  
 Insulation: Teflon  
 Impedence: 50 Ohms



**Federal Custom Cable**  
[www.FCCable.com](http://www.FCCable.com)

CAGE CODE  
1UKX3

Part Number:

Description:

**C1013**

**BNC MALE CONNECTOR CRIMP FOR RG174, RG188, RG316, B7805A CABLES**

1891 Alton Parkway, Irvine, CA 92606  
 Phone: (949) 851-3114 | Fax: (949) 852-8136  
[Sales@FCCable.com](mailto:Sales@FCCable.com)

Dimensions  
Millimeters | Inches

Scale: N/A

Revision:

NOTES:  
 1. DIMENSIONS ARE IN MILLIMETERS | INCHES  
 2. UNLESS OTHERWISE SPECIFIED ALL DIMENSIONS ARE NOMINAL  
 3. SPECIFICATIONS ARE SUBJECT TO CHANGE WITHOUT NOTICE

THIS DRAWING CONTAINS PROPRIETARY INFORMATION THAT BELONGS TO FEDERAL CUSTOM CABLE, LLC. ANY UNAUTHORIZED USE OF THIS DRAWING IS PROHIBITED WITHOUT WRITTEN PERMISSION FROM FEDERAL CUSTOM CABLE. ALL RIGHTS RESERVED. ©2016 COPYRIGHT FEDERAL CUSTOM CABLE, LLC.

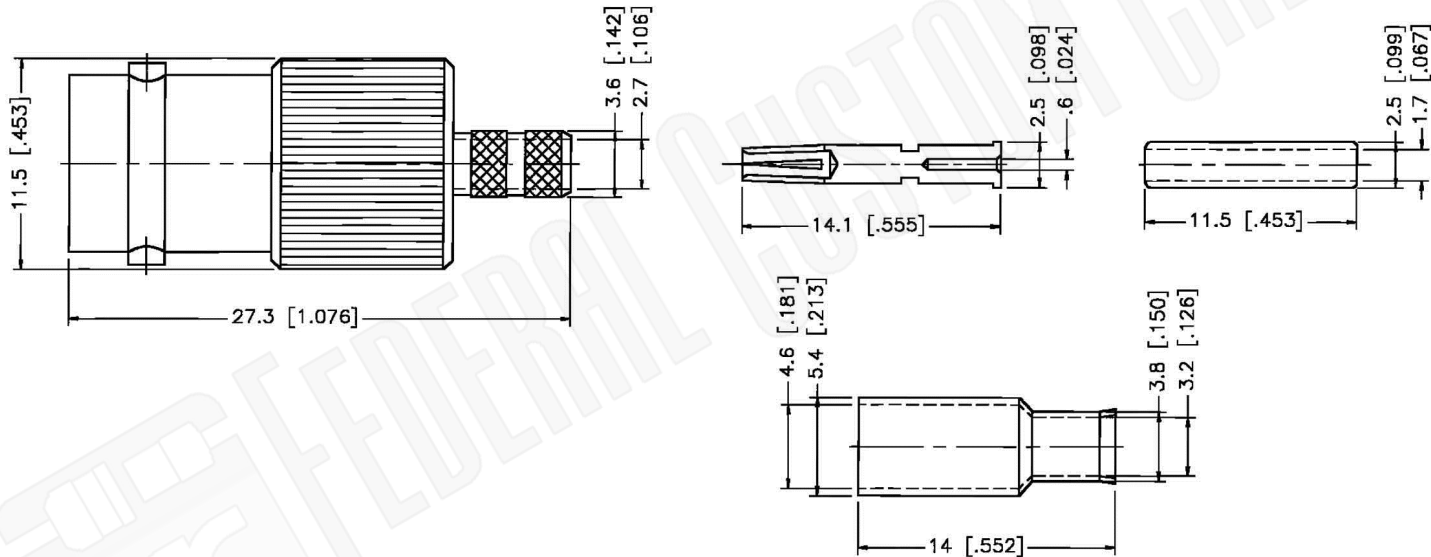
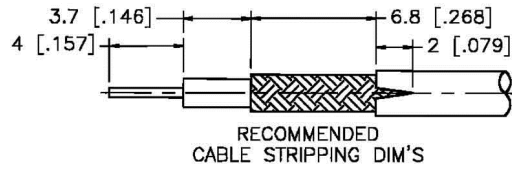

### Material Specifications

Cable(s):	RG316, U-DOUBLE BRAIDED
Body:	Brass
Finish:	Nickel
Insulation:	Teflon
Impedence:	50 Ohms



**Federal Custom Cable**  
www.FCCable.com

**CAGE CODE**  
1UKX3

**Part Number:**

**Description:**

**C1001**

**BNC FEMALE CONNECTOR CRIMP FOR RG174,  
RG188, RG316, B7805A CABLES**

1891 Alton Parkway, Irvine, CA 92606  
Phone: (949) 851-3114 | Fax: (949) 852-8136  
**Sales@FCCable.com**

**Dimensions**  
Millimeters | Inches

**Scale:** N/A

**Revision:**

**NOTES:**  
1. DIMENSIONS ARE IN MILLIMETERS | INCHES  
2. UNLESS OTHERWISE SPECIFIED ALL DIMENSIONS ARE NOMINAL  
3. SPECIFICATIONS ARE SUBJECT TO CHANGE WITHOUT NOTICE

THIS DRAWING CONTAINS PROPRIETARY INFORMATION THAT BELONGS TO FEDERAL CUSTOM CABLE, LLC. ANY UNAUTHORIZED USE OF THIS DRAWING IS PROHIBITED WITHOUT WRITTEN PERMISSION FROM FEDERAL CUSTOM CABLE. ALL RIGHTS RESERVED. ©2016 COPYRIGHT FEDERAL CUSTOM CABLE, LLC.

# RG174A/U

## 50-Ohm Flexible Coax Cable; 0.100" Diameter, Single Shield, Black PVC Jacket

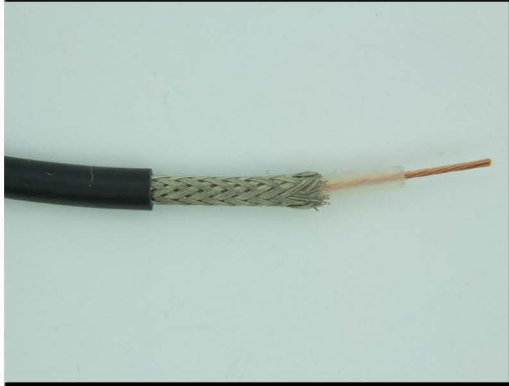

PART NUMBER:	<b>RG174A/U</b>
CATAGORY:	SEMI-RIGID
DESCRIPTION:	CABLE
IMPEDANCE:	50 OHMS
DIELECTRIC:	POLYETHYLENE
INSULATION DIAMETER:	0.060"
OVERALL DIAMETER:	0.110"

### CONDUCTOR:

AWG:	26
STRANDING:	7X34
DIAMETER:	0.0191 IN.
MATERIAL:	BCCS (BARE COPPER COVERED STEEL)

### PHYSICAL & MECHANICAL CHARACTERISTICS:

OUTER SHIELD TYPE:	BRAID
OUTER SHIELD MATERIAL:	TC (TINNED COPPER)
OUTER JACKET MATERIAL:	PVC (POLYVINYL CHLORIDE)
OPERATING TEMPERATURE RANGE:	-40 TO +75 DEGREES C
CABLE WEIGHT:	8.4 LBS/1000FT
MAXIMUM PULLING TENSION:	21 LBS.
MINIMUM BEND RADIUS (INSTALL):	1.0 IN.

### ELECTRICAL CHARACTERISTICS:

INDUCTANCE:	0.077 MICROHENRY/FT
CAPACITANCE:	30.8 pF/FT
VELOCITY OF PROPAGATION:	66%
DELAY:	1.54 NS/FT
CONDUCTOR DC RESISTANCE:	97 OHMS/1000FT @20 DEGREES C
OUTER SHIELD DC RESISTANCE:	10.7 OHMS/1000FT @ 20 DEGREES C
MAXIMUM OPERATING VOLTAGE:	1100 VRMS (MILITARY)

NOMINAL ATTENUATION:	(dB/100FT)
A. 1 MHz:	1.9
B. 100 MHz:	8.4
C. 400 MHz:	19.0
D. 700 MHz:	27.0
E. 900 MHz:	31.0
F. 1.0 GHz:	34.0

# FEDERAL CUSTOM CABLE

www.FCCABLE.com

---

## ELECTRICAL CHARACTERISTICS CONTINUED:

MAXIMUM POWER:	(WATTS)
A. 1 MHz:	976
B. 100 MHz:	161
C. 400 MHz:	120
D. 700 MHz:	112
E. 900 MHz:	109
F. 1.0 GHz:	108

1891 Alton Prkwy | Irvine, California 92606

Local Call: (949) 851-3114 | Toll Free: (888) 440-8688 | Local Fax: (949) 852-8136 | Toll Free Fax: (800)874-2444