

Material Specifications

Left Connector: C1021
 Right Connector: C2005
 Cable: RG213

NOTES:

1. XX EQUALS LENGTH IN INCHES

 Federal Custom Cable www.FCCable.com 1891 Alton Parkway, Irvine, CA 92606 Phone: (949) 851-3114 Fax: (949) 852-8136 Sales@FCCable.com	CAGE CODE 1UKX3	Part Number: CA1026-XX	Description: BNC MALE TO BNC FEMALE COAX CABLE ASSEMBLY WITH RG213 FLEXIBLE CABLE
	Dimensions Millimeters Inches		
	Scale: N/A	NOTES: 1. DIMENSIONS ARE IN MILLIMETERS INCHES 2. UNLESS OTHERWISE SPECIFIED ALL DIMENSIONS ARE NOMINAL 3. SPECIFICATIONS ARE SUBJECT TO CHANGE WITHOUT NOTICE	THIS DRAWING CONTAINS PROPRIETART INFORMATION THAT BELONGS TO FEDERAL CUSTOM CABLE, LLC. ANY UNAUTHORIZED USE OF THIS DRAWING IS PROHIBITED WITHOUT WRITTEN PERMISSION FROM FEDERAL CUSTOM CABLE. ALL RIGHTS RESERVED. ©2020 COPYRIGHT FEDERAL CUSTOM CABLE, LLC.
	Revision:		

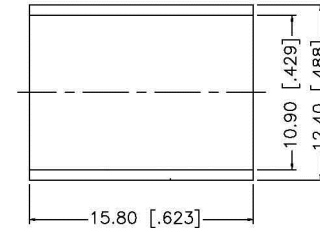
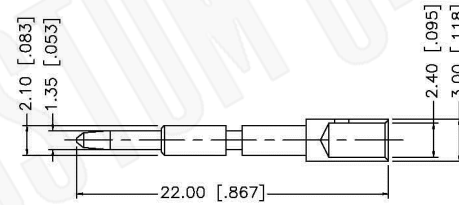
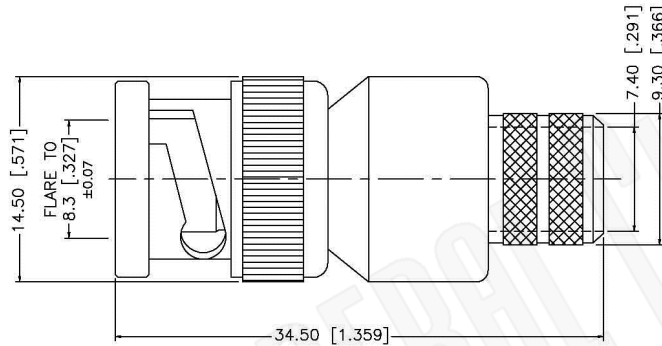
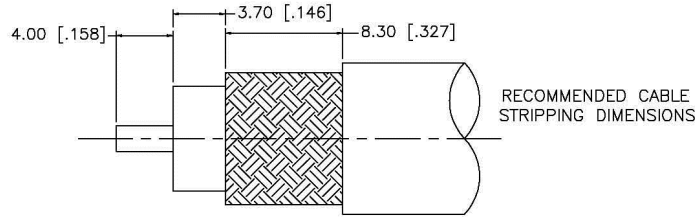

CRIMP NOTES:

1. CRIMPED FERRULE
HEX CRIMP SIZE .429"
2. CRIMPED CONTACT PIN
HEX CRIMP SIZE .100"

Material Specifications

Cable(s): RG8, 8A, 213, 393
 Body: Brass
 Finish: Nickel
 Insulation: Teflon
 Impedence: 50 Ohms



Federal Custom Cable
www.FCCable.com
 1891 Alton Parkway, Irvine, CA 92606
 Phone: (949) 851-3114 | Fax: (949) 852-8136
Sales@FCCable.com

CAGE CODE
1UKX3

Dimensions
Millimeters | Inches

Scale: N/A

Revision:

Part Number:
C1021

NOTES:
 1. DIMENSIONS ARE IN MILLIMETERS | INCHES
 2. UNLESS OTHERWISE SPECIFIED ALL DIMENSIONS ARE NOMINAL
 3. SPECIFICATIONS ARE SUBJECT TO CHANGE WITHOUT NOTICE

Description:
BNC MALE CONNECTOR CRIMP FOR RG8, RG213, RG393 CABLES

THIS DRAWING CONTAINS PROPRIETARY INFORMATION THAT BELONGS TO FEDERAL CUSTOM CABLE, LLC. ANY UNAUTHORIZED USE OF THIS DRAWING IS PROHIBITED WITHOUT WRITTEN PERMISSION FROM FEDERAL CUSTOM CABLE. ALL RIGHTS RESERVED. ©2016 COPYRIGHT FEDERAL CUSTOM CABLE, LLC.

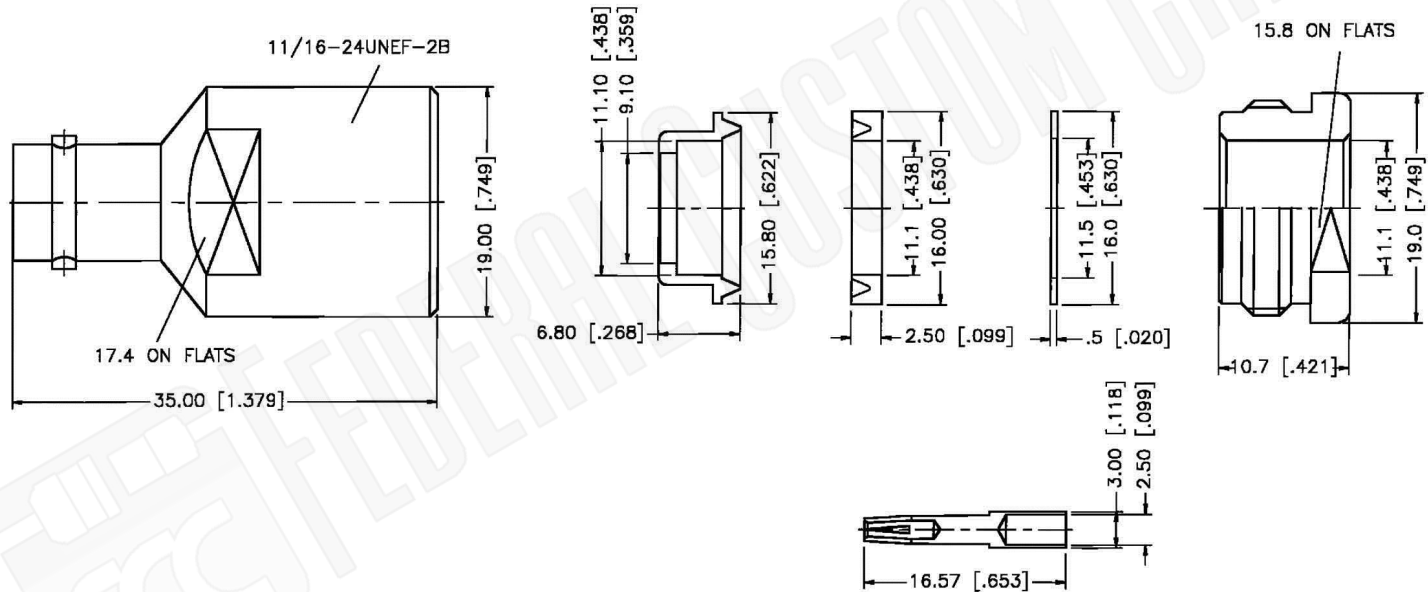
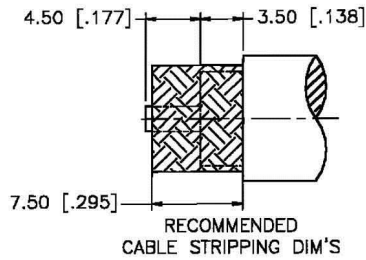

Material Specifications

Cable(s): RG8, 8A, 213, 393
 Body: Brass
 Finish: Nickel
 Insulation: Teflon
 Impedence: 50 Ohms



Federal Custom Cable
www.FCCable.com

CAGE CODE
 1UKX3

Part Number:

Description:

C2005

**BNC FEMALE CONNECTOR CLAMP FOR RG8, RG9,
 RG11, RG213, RG214, RG225, RG393 CABLES**

1891 Alton Parkway, Irvine, CA 92606
 Phone: (949) 851-3114 | Fax: (949) 852-8136
Sales@FCCable.com

Dimensions
 Millimeters | Inches

Scale: N/A

Revision:

NOTES:
 1. DIMENSIONS ARE IN MILLIMETERS | INCHES
 2. UNLESS OTHERWISE SPECIFIED ALL DIMENSIONS ARE NOMINAL
 3. SPECIFICATIONS ARE SUBJECT TO CHANGE WITHOUT NOTICE

THIS DRAWING CONTAINS PROPRIETARY INFORMATION THAT BELONGS TO FEDERAL CUSTOM CABLE, LLC. ANY UNAUTHORIZED USE OF THIS DRAWING IS PROHIBITED WITHOUT WRITTEN PERMISSION FROM FEDERAL CUSTOM CABLE. ALL RIGHTS RESERVED. ©2016 COPYRIGHT FEDERAL CUSTOM CABLE, LLC.

RG213/U

50-Ohm Flexible Coax Cable; 0.405" Diameter, Single Shield, Black PVC Jacket

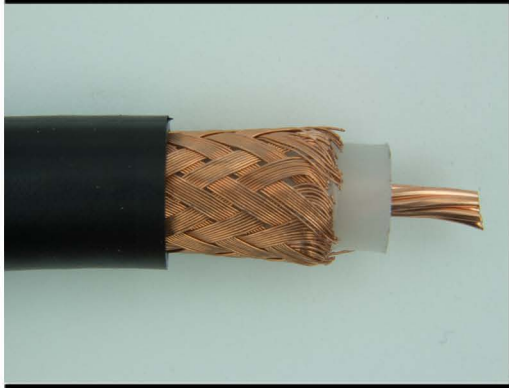

PART NUMBER:	RG213/U
CATAGORY:	FLEXIBLE
DESCRIPTION:	CABLE
IMPEDANCE:	50 OHMS
DIELECTRIC:	POLYETHYLENE
OUTSIDE DIAMETER:	0.285
NOMINAL OUTSIDE DIAMETER:	0.405

DIMENSIONS:

QUALIFICATION:	M17/74-RG213 SWEPT ATTN/STRUCTURAL RETURN LOSS 50 TO 1000 MHz
INNER CONDUCTOR:	DIAMETER 0.0888; 7/0.0296 BARE COPPER, 13 AWG, 1.76 OHM/1000FT. NOMINAL DIRECT CURRENT RESISTANCE
OUTER CONDUCTOR & TYPE OF SHIELD:	95% BARE COPPER, 2.9 OHM/1000FT.
JACKET MATERIAL:	POLYVINYL CHLORIDE-II A, BLACK
OVER BRAID & OUTSIDE DIAMETER:	N/A

ELECTRICAL CHARACTERISTICS:

NOMINAL CAPACITANCE (PICO FARAD/FT):	30.8
VELOCITY OF PROPAGATION:	66%
MAXIMUM OPERATING FREQUENCY (GHz):	1.0
MAXIMUM OPERATING RANGE (C):	-40 TO +85
MAXIMUM ATTENUATION:	dB (MHz/100ft)
A. 50 MHz:	1.2
B. 100 MHz:	2.3
C. 200 MHz:	3.2
D. 400 MHz:	4.8
E. 1000 MHz:	9.0
QUALIFICATION TEST REPORT#:	17-003-91
APPROX WT/1000FT:	111 LBS.