

Material Specifications

Left Connector: C1094
 Right Connector: C1137
 Cable: RG142

NOTES:

1. XX EQUALS LENGTH IN INCHES

| | | | |
|---|------------------------------------|---|---|
|  Federal Custom Cable www.FCCable.com 1891 Alton Parkway, Irvine, CA 92606 Phone: (949) 851-3114 Fax: (949) 852-8136 Sales@FCCable.com | CAGE CODE 1UKX3 | Part Number: CA1393-XX | Description: N MALE RIGHT ANGLE TO SMA MALE CABLE ASSEMBLY WITH RG142 CABLE |
| | Dimensions Millimeters Inches | | |
| | Scale: N/A | NOTES: 1. DIMENSIONS ARE IN MILLIMETERS INCHES 2. UNLESS OTHERWISE SPECIFIED ALL DIMENSIONS ARE NOMINAL 3. SPECIFICATIONS ARE SUBJECT TO CHANGE WITHOUT NOTICE | THIS DRAWING CONTAINS PROPRIETARY INFORMATION THAT BELONGS TO FEDERAL CUSTOM CABLE, LLC. ANY UNAUTHORIZED USE OF THIS DRAWING IS PROHIBITED WITHOUT WRITTEN PERMISSION FROM FEDERAL CUSTOM CABLE. ALL RIGHTS RESERVED. ©2020 COPYRIGHT FEDERAL CUSTOM CABLE, LLC. |
| | Revision: | | |

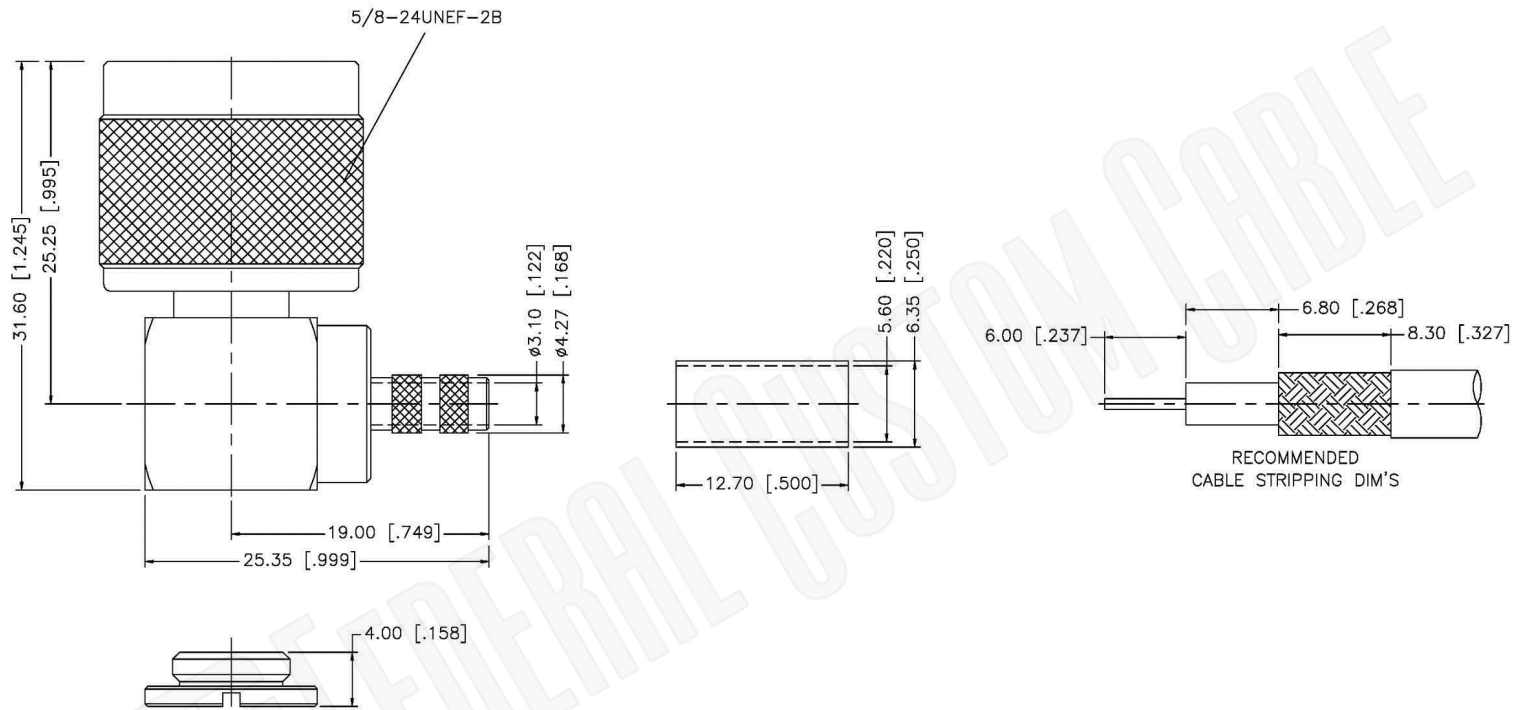

- NOTE:
1. CRIMPED FERRULE
HEX. CRIMP SIZE .213"
 2. CONTACT PIN TO SOLDER.

Material Specifications

Cable(s): RG55,142,223,400
 Body: Brass
 Finish: White Bronze
 Insulation: Teflon
 Impedence: 50 Ohms



Federal Custom Cable
www.FCCable.com

CAGE CODE
 1UKX3

Part Number:

Description:

C1094

**N MALE CONNECTOR RIGHT ANGLE CRIMP FOR
 RG55, RG142, RG223, RG400 CABLES**

1891 Alton Parkway, Irvine, CA 92606
 Phone: (949) 851-3114 | Fax: (949) 852-8136
Sales@FCCable.com

Dimensions
 Millimeters | Inches

Scale: N/A

Revision:

NOTES:
 1. DIMENSIONS ARE IN MILLIMETERS | INCHES
 2. UNLESS OTHERWISE SPECIFIED ALL DIMENSIONS ARE NOMINAL
 3. SPECIFICATIONS ARE SUBJECT TO CHANGE WITHOUT NOTICE

THIS DRAWING CONTAINS PROPRIETARY INFORMATION THAT BELONGS TO FEDERAL CUSTOM CABLE, LLC. ANY UNAUTHORIZED USE OF THIS DRAWING IS PROHIBITED WITHOUT WRITTEN PERMISSION FROM FEDERAL CUSTOM CABLE. ALL RIGHTS RESERVED. ©2016 COPYRIGHT FEDERAL CUSTOM CABLE, LLC.

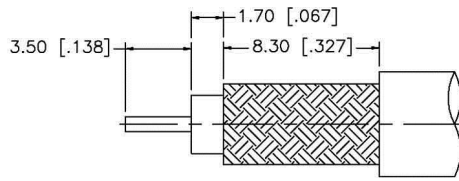

RECOMMENDED CABLE STRIPPING DIMENSIONS

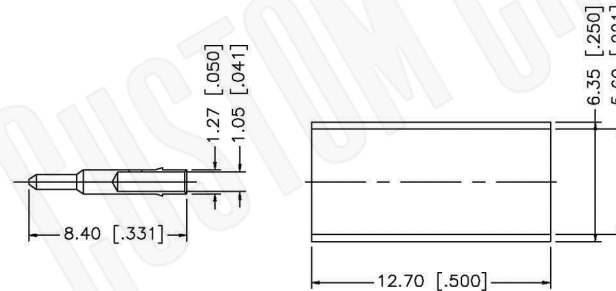
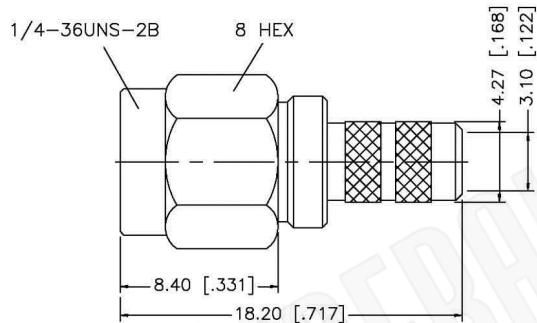

CRIMP NOTES:

1. CRIMPED FERRULE
HEX CRIMP SIZE .213"
2. SOLDER CENTER CONTACT

Material Specifications

Cable(s): RG55,142,223,400
 Body: Brass
 Finish: Gold
 Insulation: Teflon
 Impedence: 50 Ohms



Federal Custom Cable
www.FCCable.com

CAGE CODE
1UKX3

Part Number:

Description:

C1137

**SMA MALE CONNECTOR CRIMP FOR RG55, RG142,
 RG223, RG400 CABLES**

Dimensions
Millimeters | Inches

Scale: N/A

Revision:

NOTES:
 1. DIMENSIONS ARE IN MILLIMETERS | INCHES
 2. UNLESS OTHERWISE SPECIFIED ALL DIMENSIONS ARE NOMINAL
 3. SPECIFICATIONS ARE SUBJECT TO CHANGE WITHOUT NOTICE

THIS DRAWING CONTAINS PROPRIETARY INFORMATION THAT BELONGS TO FEDERAL CUSTOM CABLE, LLC. ANY UNAUTHORIZED USE OF THIS DRAWING IS PROHIBITED WITHOUT WRITTEN PERMISSION FROM FEDERAL CUSTOM CABLE. ALL RIGHTS RESERVED. ©2016 COPYRIGHT FEDERAL CUSTOM CABLE, LLC.

1891 Alton Parkway, Irvine, CA 92606
 Phone: (949) 851-3114 | Fax: (949) 852-8136

Sales@FCCable.com

RG142B/U

50-Ohm Flexible Coax Cable; 0.195" Diameter, Single Shield, Tan FEP Jacket

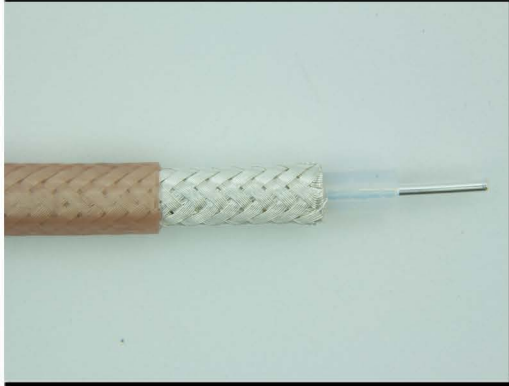

| | |
|----------------------|-----------------|
| PART NUMBER: | RG142B/U |
| CATAGORY: | FLEXIBLE |
| DESCRIPTION: | CABLE |
| IMPEDANCE: | 50 OHMS |
| DIELECTRIC: | TEFLON |
| OVERALL DIAMETER: | 0.195" |
| DIELECTRIC DIAMETER: | 0.116" |

PHYSICAL CHARACTERISTICS:

| | |
|------------------------|---|
| SHIELD: | DOUBLE BRAID SILVER PLATED COPPER |
| JACKET: | FLUORINATED ETHYLENE PROPYLENE |
| OPERATING TEMPERATURE: | -55 C TO +200 C |
| WEIGHT: | 43 LBS/1000FT |
| CENTER CONDUCTOR: | 0.037" DIAMETER (SILVER PLATED COPPER-CLAD STEEL) |

ELECTRICAL CHARACTERISTICS:

| | |
|----------------------------|----------------|
| CAPACITANCE: | 29.4 PFARAD/FT |
| MAXIMUM OPERATING VOLTAGE: | 1900 VRMS |
| MAXIMUM ATTENUATION: | (dB/100ft) |
| A. 100 MHz: | 5.5 |
| B. 400 MHz: | 11.7 |
| C. 1 GHz: | 19.0 |
| D. 3 GHz: | 35.0 |
| E. 5 GHz: | 48.0 |
| MAXIMUM FREQUENCY (GHz): | 12.4 |
| MAXIMUM POWER: | |
| A. 400 MHz: | 110 |
| B. 1 GHz: | 550 |
| C. 3 GHz: | 350 |
| D. 5 GHz: | 245 |
| E. 10 GHz: | 140 |