

Material Specifications

Left Connector: C1127
 Right Connector: C1115
 Cable: RG174

NOTES:

1. XX EQUALS LENGTH IN INCHES

 Federal Custom Cable www.FCCable.com 1891 Alton Parkway, Irvine, CA 92606 Phone: (949) 851-3114 Fax: (949) 852-8136 Sales@FCCable.com	CAGE CODE 1UKX3	Part Number: CA1491-XX	Description: SMA MALE TO SMA FEMALE BULKHEAD CABLE ASSEMBLY WITH RG174 CABLE
	Dimensions Millimeters Inches		
	Scale: N/A	NOTES: 1. DIMENSIONS ARE IN MILLIMETERS INCHES 2. UNLESS OTHERWISE SPECIFIED ALL DIMENSIONS ARE NOMINAL 3. SPECIFICATIONS ARE SUBJECT TO CHANGE WITHOUT NOTICE	THIS DRAWING CONTAINS PROPRIETART INFORMATION THAT BELONGS TO FEDERAL CUSTOM CABLE, LLC. ANY UNAUTHORIZED USE OF THIS DRAWING IS PROHIBITED WITHOUT WRITTEN PERMISSION FROM FEDERAL CUSTOM CABLE. ALL RIGHTS RESERVED. ©2020 COPYRIGHT FEDERAL CUSTOM CABLE, LLC.
	Revision:		

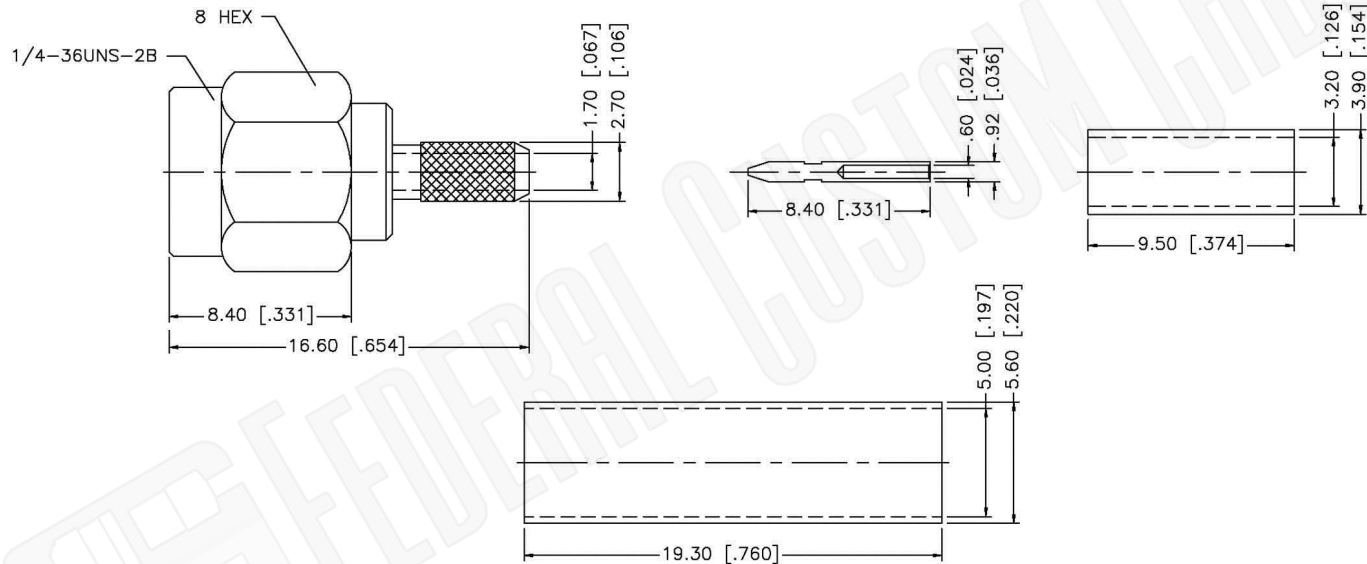
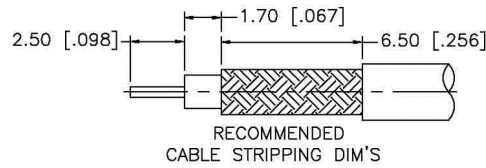

NOTE:
1. CRIMPED FERRULE
HEX CRIMP SIZE .128"

Material Specifications

Cable(s): RG174, 188A, 316, B7805A
 Body: Brass
 Finish: Gold
 Insulation: Teflon
 Impedence: 50 Ohms



Federal Custom Cable
www.FCCable.com
 1891 Alton Parkway, Irvine, CA 92606
 Phone: (949) 851-3114 | Fax: (949) 852-8136
Sales@FCCable.com

CAGE CODE 1UKX3	
Dimensions Millimeters Inches	
Scale:	N/A
Revision:	

Part Number:
C1127

NOTES:
1. DIMENSIONS ARE IN MILLIMETERS | INCHES
2. UNLESS OTHERWISE SPECIFIED ALL DIMENSIONS ARE NOMINAL
3. SPECIFICATIONS ARE SUBJECT TO CHANGE WITHOUT NOTICE

Description:
**SMA MALE CONNECTOR CRIMP FOR RG174, RG188,
RG316, B7805A CABLES**

THIS DRAWING CONTAINS PROPRIETARY INFORMATION THAT BELONGS TO FEDERAL CUSTOM CABLE, LLC. ANY UNAUTHORIZED USE OF THIS DRAWING IS PROHIBITED WITHOUT WRITTEN PERMISSION FROM FEDERAL CUSTOM CABLE.
ALL RIGHTS RESERVED. ©2016 COPYRIGHT FEDERAL CUSTOM CABLE, LLC.

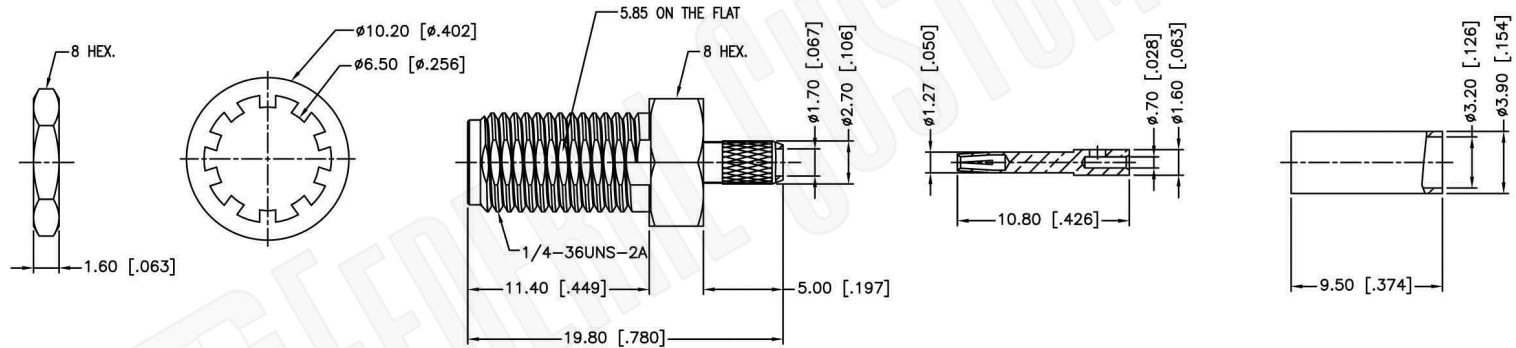
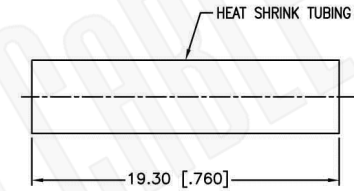
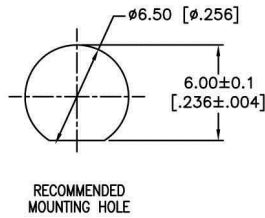
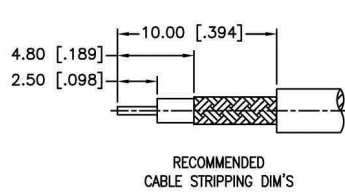

NOTE:
 1. CRIMPED FERRULE HEX CRIMP SIZE .128"
 2. CONTACT PIN TO SOLDER
 3. MAX. PANEL THICKNESS=3.2mm

Material Specifications

Cable(s): RG174, 188A, 316, B7805A
 Body: Brass
 Finish: Gold
 Insulation: Teflon
 Impedence: 50 Ohms



Federal Custom Cable
www.FCCable.com
 1891 Alton Parkway, Irvine, CA 92606
 Phone: (949) 851-3114 | Fax: (949) 852-8136
Sales@FCCable.com

CAGE CODE
1UKX3

Dimensions
Millimeters | Inches

Scale: N/A

Revision:

Part Number:
C1115

NOTES:
 1. DIMENSIONS ARE IN MILLIMETERS | INCHES
 2. UNLESS OTHERWISE SPECIFIED ALL DIMENSIONS ARE NOMINAL
 3. SPECIFICATIONS ARE SUBJECT TO CHANGE WITHOUT NOTICE

Description:
**SMA FEMALE CONNECTOR BULKHEAD CRIMP FOR
 RG174, RG188, RG316, B7805A CABLES**

THIS DRAWING CONTAINS PROPRIETARY INFORMATION THAT BELONGS TO FEDERAL CUSTOM CABLE, LLC. ANY UNAUTHORIZED USE OF THIS DRAWING IS PROHIBITED WITHOUT WRITTEN PERMISSION FROM FEDERAL CUSTOM CABLE. ALL RIGHTS RESERVED. ©2016 COPYRIGHT FEDERAL CUSTOM CABLE, LLC.

RG174A/U

50-Ohm Flexible Coax Cable; 0.100" Diameter, Single Shield, Black PVC Jacket

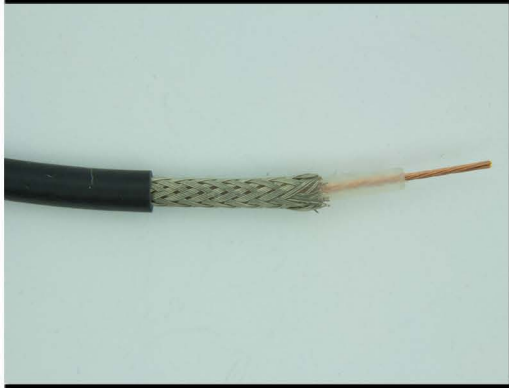

PART NUMBER:	RG174A/U
CATAGORY:	SEMI-RIGID
DESCRIPTION:	CABLE
IMPEDANCE:	50 OHMS
DIELECTRIC:	POLYETHYLENE
INSULATION DIAMETER:	0.060"
OVERALL DIAMETER:	0.110"

CONDUCTOR:

AWG:	26
STRANDING:	7X34
DIAMETER:	0.0191 IN.
MATERIAL:	BCCS (BARE COPPER COVERED STEEL)

PHYSICAL & MECHANICAL CHARACTERISTICS:

OUTER SHIELD TYPE:	BRAID
OUTER SHIELD MATERIAL:	TC (TINNED COPPER)
OUTER JACKET MATERIAL:	PVC (POLYVINYL CHLORIDE)
OPERATING TEMPERATURE RANGE:	-40 TO +75 DEGREES C
CABLE WEIGHT:	8.4 LBS/1000FT
MAXIMUM PULLING TENSION:	21 LBS.
MINIMUM BEND RADIUS (INSTALL):	1.0 IN.

ELECTRICAL CHARACTERISTICS:

INDUCTANCE:	0.077 MICROHENRY/FT
CAPACITANCE:	30.8 pF/FT
VELOCITY OF PROPAGATION:	66%
DELAY:	1.54 NS/FT
CONDUCTOR DC RESISTANCE:	97 OHMS/1000FT @20 DEGREES C
OUTER SHIELD DC RESISTANCE:	10.7 OHMS/1000FT @ 20 DEGREES C
MAXIMUM OPERATING VOLTAGE:	1100 VRMS (MILITARY)

NOMINAL ATTENUATION:	(dB/100FT)
A. 1 MHz:	1.9
B. 100 MHz:	8.4
C. 400 MHz:	19.0
D. 700 MHz:	27.0
E. 900 MHz:	31.0
F. 1.0 GHz:	34.0

FEDERAL CUSTOM CABLE

www.FCCABLE.com

ELECTRICAL CHARACTERISTICS CONTINUED:

MAXIMUM POWER:	(WATTS)
A. 1 MHz:	976
B. 100 MHz:	161
C. 400 MHz:	120
D. 700 MHz:	112
E. 900 MHz:	109
F. 1.0 GHz:	108

1891 Alton Prkwy | Irvine, California 92606

Local Call: (949) 851-3114 | Toll Free: (888) 440-8688 | Local Fax: (949) 852-8136 | Toll Free Fax: (800)874-2444