

Material Specifications

Left Connector: C1194
 Right Connector: C1197
 Cable: RG58

NOTES:

1. XX EQUALS LENGTH IN INCHES

 Federal Custom Cable www.FCCable.com 1891 Alton Parkway, Irvine, CA 92606 Phone: (949) 851-3114 Fax: (949) 852-8136 Sales@FCCable.com	CAGE CODE 1UKX3	Part Number: CA2093-XX	Description: TNC FEMALE BULKHEAD TO TNC MALE CABLE ASSEMBLY WITH RG58 CABLE
	Dimensions Millimeters Inches		
	Scale: N/A	NOTES: 1. DIMENSIONS ARE IN MILLIMETERS INCHES 2. UNLESS OTHERWISE SPECIFIED ALL DIMENSIONS ARE NOMINAL 3. SPECIFICATIONS ARE SUBJECT TO CHANGE WITHOUT NOTICE	THIS DRAWING CONTAINS PROPRIETARY INFORMATION THAT BELONGS TO FEDERAL CUSTOM CABLE, LLC. ANY UNAUTHORIZED USE OF THIS DRAWING IS PROHIBITED WITHOUT WRITTEN PERMISSION FROM FEDERAL CUSTOM CABLE. ALL RIGHTS RESERVED. ©2020 COPYRIGHT FEDERAL CUSTOM CABLE, LLC.
	Revision:		

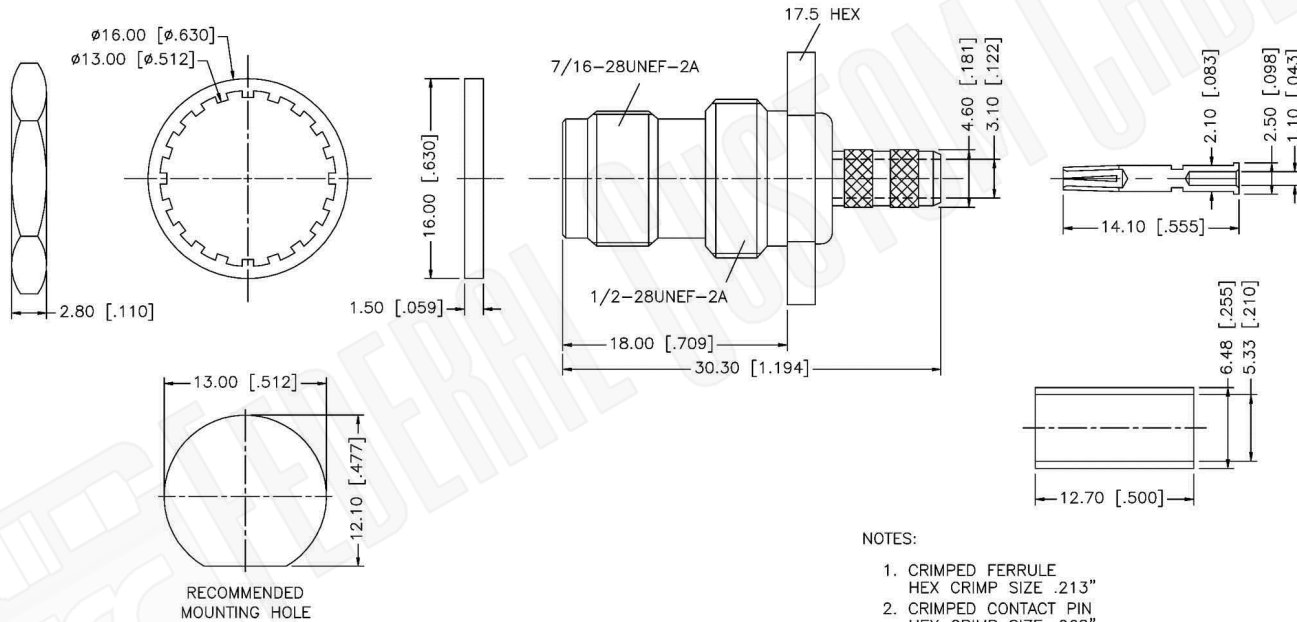
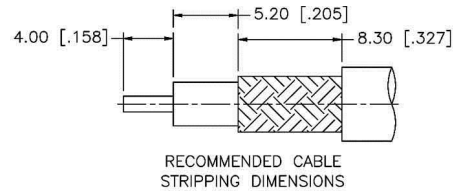

NOTES:

1. CRIMPED FERRULE
HEX CRIMP SIZE .213"
2. CRIMPED CONTACT PIN
HEX CRIMP SIZE .068"
3. MAX. PANEL THICKNESS = 3.5mm

Material Specifications

Cable(s): RG58,58A,58C,141,303,LMR195,B7806A
 Body: Brass
 Finish: Nickel
 Insulation: Teflon
 Impedence: 50 Ohms



Federal Custom Cable
www.FCCable.com
 1891 Alton Parkway, Irvine, CA 92606
 Phone: (949) 851-3114 | Fax: (949) 852-8136
Sales@FCCable.com

CAGE CODE
1UKX3

Dimensions
Millimeters | Inches

Scale: N/A

Revision:

Part Number:
C1194

NOTES:
 1. DIMENSIONS ARE IN MILLIMETERS | INCHES
 2. UNLESS OTHERWISE SPECIFIED ALL DIMENSIONS ARE NOMINAL
 3. SPECIFICATIONS ARE SUBJECT TO CHANGE WITHOUT NOTICE

Description:
**TNC FEMALE CONNECTOR BULKHEAD CRIMP FOR
 RG58, RG141, RG303, LMR195, B7806A CABLES**

THIS DRAWING CONTAINS PROPRIETARY INFORMATION THAT BELONGS TO FEDERAL CUSTOM CABLE, LLC. ANY UNAUTHORIZED USE OF THIS DRAWING IS PROHIBITED WITHOUT WRITTEN PERMISSION FROM FEDERAL CUSTOM CABLE.
 ALL RIGHTS RESERVED. ©2016 COPYRIGHT FEDERAL CUSTOM CABLE, LLC.

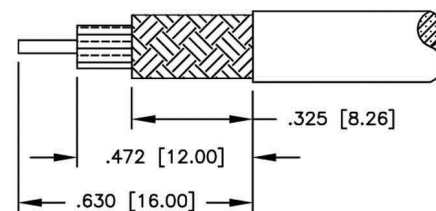
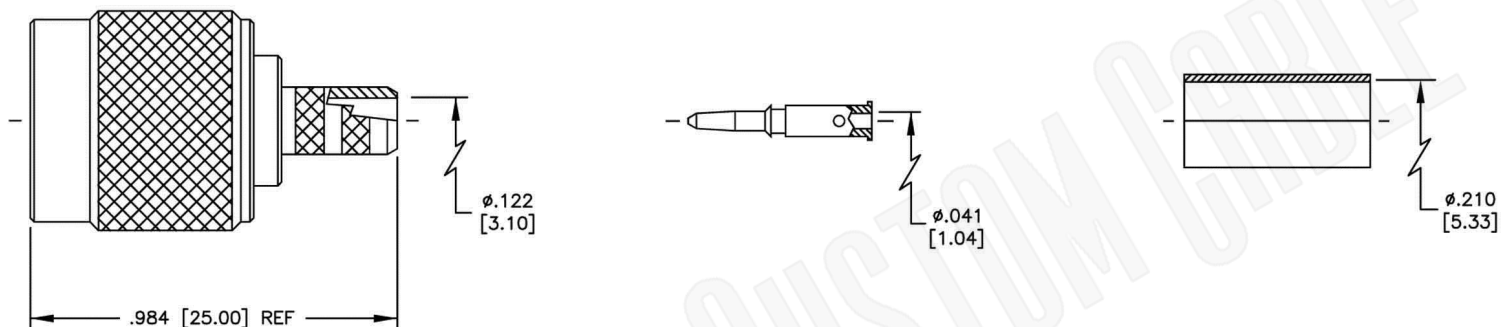

SUGGESTED STRIPPING INSTRUCTIONS
SUGGESTED CRIMP DIES: .068 & .213

Material Specifications

Cable(s): RG58,58A,58C,141,303,LMR195,B7806A
 Body: Brass
 Finish: Nickel
 Insulation: Delrin
 Impedence: 50 Ohms



FCC Federal Custom Cable
 www.FCCable.com
 1891 Alton Parkway, Irvine, CA 92606
 Phone: (949) 851-3114 | Fax: (949) 852-8136
 Sales@FCCable.com

CAGE CODE 1UKX3
Dimensions Millimeters Inches
Scale: N/A
Revision:

Part Number:
C1197

NOTES:
 1. DIMENSIONS ARE IN MILLIMETERS | INCHES
 2. UNLESS OTHERWISE SPECIFIED ALL DIMENSIONS ARE NOMINAL
 3. SPECIFICATIONS ARE SUBJECT TO CHANGE WITHOUT NOTICE

Description:
TNC MALE CONNECTOR CRIMP FOR RG58, RG141, RG303, LMR195, B7806A CABLES

THIS DRAWING CONTAINS PROPRIETARY INFORMATION THAT BELONGS TO FEDERAL CUSTOM CABLE, LLC. ANY UNAUTHORIZED USE OF THIS DRAWING IS PROHIBITED WITHOUT WRITTEN PERMISSION FROM FEDERAL CUSTOM CABLE.
 ALL RIGHTS RESERVED. ©2016 COPYRIGHT FEDERAL CUSTOM CABLE, LLC.

RG58C/U

50-Ohm Flexible Coax Cable; 0.195" Diameter, Single Shield, Black PVC(NC) Jacket



PART NUMBER:	RG58C/U
CATAGORY:	FLEXIBLE
DESCRIPTION:	CABLE
IMPEDANCE:	50 OHMS
DIELECTRIC:	POLYETHYLENE
OUTSIDE DIAMETER:	0.116"
NOMINAL OUTSIDE DIAMETER:	0.195"
QUALIFICATION:	M17/28-RG058 SWEPT ATTN/STRUCTURALRETURN LOSS 1000 MHz

PHYSICAL CHARACTERISTICS:

OUTER CONDUCTOR &TYPE OF SHIELD:	95% TINNED COPPER, 4.1 OHM/1000FT
JACKET MATERIAL:	POLYVINYL CHLORIDE-II A, BLACK
OVER-BRAID:	N/A
INNER CONDUCTOR:	0.0355; 19/0.00072 TINNED COPPER, 20 AWG, 12.4 OHM/1000FT NOMINAL DIRECT CURRENT RESISTANCE

ELECTRICAL CHARACTERISTICS:

NOMINAL CAPACITANCE (PICO FARAD/FT):	30.8
VELOCITY OF PROPAGATION:	66%
MAXIMUM OPERATING FREQUENCY (GHz):	1.0
MAXIMUM OPERATING RANGE (C):	-40 TO +85
MAXIMUM ATTENUATION:	dB (MHz/100ft)
A. 50 MHz:	4.0
B. 100 MHz:	6.5
C. 200 MHz:	8.0
D. 400 MHz:	17.0
E. 1000 MHz:	28.0
QUALIFICATION TEST REPORT#:	17-395-90
APPROX WT/1000FT:	26 LBS.